

## EE 330/330L Energy Systems (Spring 2012)

### Laboratory 3 Three-Phase Transformers

#### Introduction/Background

In this laboratory, you will determine the input/output voltages and equivalent turns ratios for three small single-phase transformers connected in a variety of configurations.

#### Experiment 1 Initial Set-up

- 1) Record the nameplate data for each of the transformers being tested (label them as #1, #2, and #3).
- 2) Configure each of the transformers in a 2:1 step-down configuration by connecting the high voltage coils in series, i.e., tie jack H2 to H3, and the low voltage coils in parallel, i.e., tie jack X1 to X3 and jack X2 to X4, as shown in Figure 1.

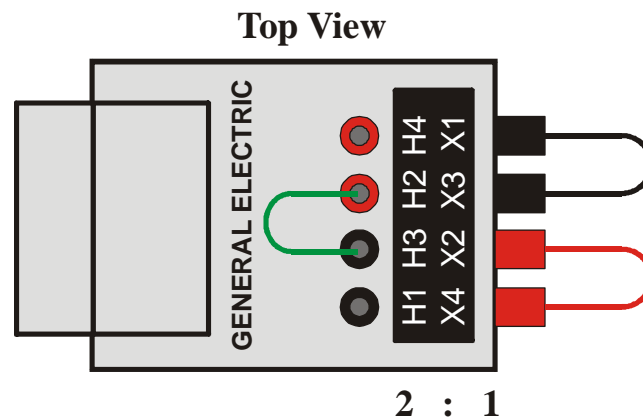

**Figure 1** Transformer connections for 2:1 step-down configuration.

- 3) For each of the transformers, use an ohmmeter (multimeter) to measure and record the dc wire resistance of the high voltage coils  $R_{w,H\#}$  (i.e., the resistance between jacks H1 and H4) and that of the low voltage coils  $R_{w,L\#}$  (i.e., the resistance between jacks X1 and X4).
- 4) Successively perform open circuit voltage tests on each of the transformers. A block diagram of the necessary connections, including the voltmeters, is shown in Figure 2. Do **NOT** plug in the power cord until all connections have been made, variac set to zero, and three-phase breaker set to 'off'. After plugging in the three-phase power cord and setting the three-phase breaker to 'on', use the variac to slowly raise the applied voltage to  $\sim 100 V_{\text{rms}}$ . Then, measure and record  $V_{\text{oc},H\#}$  (i.e., voltage between jacks H1 and H4) and  $V_{\text{oc},L\#}$  (i.e., voltage between jack pairs X1 and X4). Use this information to calculate the turns ratio  $a_{\#}$  for this transformer. When changing out transformers, use the variac to reduce the applied voltage to zero, and set the three-phase breaker to 'off'. When finished, unplug the power cord. Do **NOT** disconnect any other wires until reading the next experiment.
- 5) Tabulate the data taken/calculated in steps 3) and 4). Format- column 1 is description of quantity of interest (e.g.,  $R_{w,H}$ ,  $R_{w,L}$ ,  $V_{\text{oc},H}$ ,  $V_{\text{oc},L}$ , and  $a$ ), column 2 values for transformer #1, column 3 values for transformer #2, and column 4 values for transformer #3.

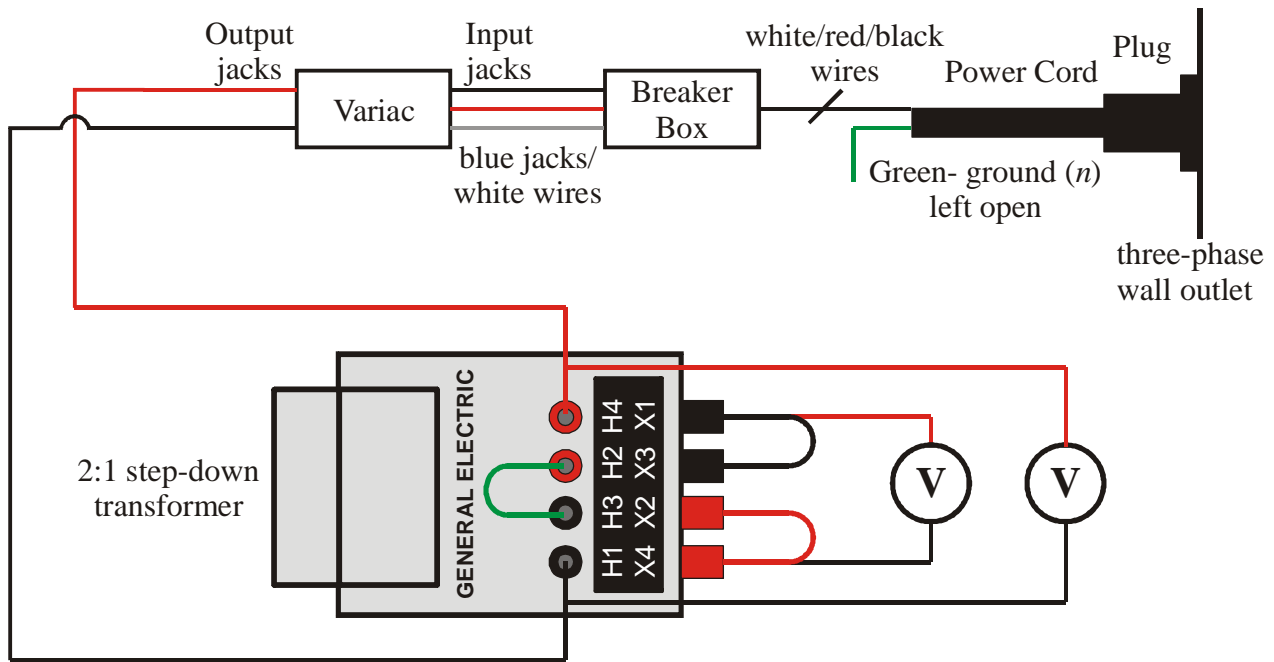

**Figure 2** Connections for open circuit voltage tests on the individual transformers.

### Experiment 2 3-phase Wye-Wye (Y-Y) Configuration

- 1) A block diagram of the necessary connections is shown in Figure 3. In this case, the voltmeter connections have been omitted for clarity. Do **NOT** plug in the power cord until all connections have been made, variac set to zero, and three-phase breaker set to 'off'. After plugging in the three-phase power cord and setting the three-phase breaker to 'on', use the variac to slowly raise the applied voltage to  $\sim 100 V_{\text{rms}}$ .

**Note: The applied voltage always refers to the line-to-line voltages supplied by the variac.**

- 2) Then, measure and record the primary phase voltages (e.g.,  $V_{an}$ ,  $V_{bn}$ , and  $V_{cn}$ ), secondary phase voltages (e.g.,  $V_{a'n}$ ,  $V_{b'n}$ , and  $V_{c'n}$ ), primary line-to-line voltages (e.g.,  $V_{ab}$ ,  $V_{bc}$ , and  $V_{ca}$ ), secondary line-to-line voltages (e.g.,  $V_{a'b'}$ ,  $V_{b'c'}$ , and  $V_{c'a'}$ ), primary neutral current  $I_n$ , and secondary neutral current  $I_n$ . When done, use the variac to reduce the applied voltage to zero, set the three-phase breaker to 'off', and unplug the power cord. Do NOT disconnect any other wires until reading the next experiment.
- 3) Use this information to calculate the line-to-line turns ratios  $a_{Y-Y}$  and phase turns ratios  $a_\phi$  for each appropriate voltage pair.
- 4) Tabulate the data taken/calculated in steps 2) and 3). Format- column 1 is description of quantity of interest in the order taken or calculated (e.g.,  $V_{an}$ , ...), column 2 is the actual values, column 3 is for comparable values from Experiment 1 or predicted values using text (if applicable), and column 4 is for % difference (e.g., (% diff. =  $|\text{meas.} - \text{predicted}/\text{comparable}|/\text{measured} * 100\%$ ).
- 5) Determine the ratio of the average line-to-line turns ratio  $a_{Y-Y, \text{ave}}$  to the average phase turns ratio  $a_{\phi, \text{ave}}$ . How does this ratio compare to theory?

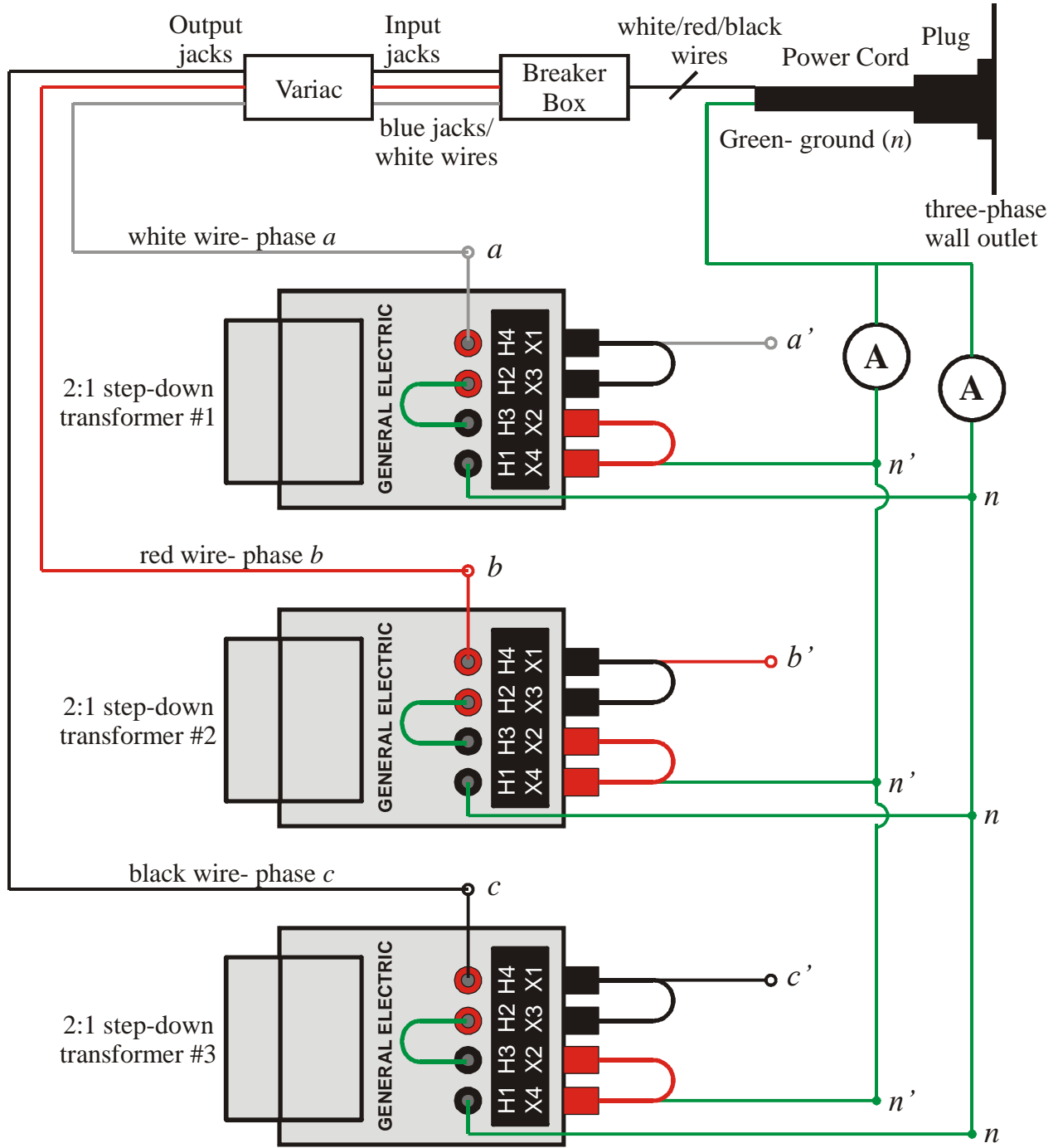

**Figure 3** 3-phase transformer connections for open circuit voltage tests on the Y-Y configuration.

**Experiment 3 3-phase Wye-Delta (Y- $\Delta$ ) Configuration**

- 1) A block diagram of the necessary connections is shown in Figure 4. In this case, the voltmeter connections have been omitted for clarity. Do **NOT** plug in the power cord until all connections have been made, variac set to zero, and three-phase breaker set to 'off'. After plugging in the three-phase power cord and setting the three-phase breaker to 'on', use the variac to slowly raise the applied voltage to  $\sim 100 V_{\text{rms}}$ .
- 2) Then, measure and record the primary phase voltages (e.g.,  $V_{an}$ ,  $V_{bn}$ , and  $V_{cn}$ ), primary line-to-line voltages (e.g.,  $V_{ab}$ ,  $V_{bc}$ , and  $V_{ca}$ ), secondary line-to-line/phase voltages (e.g.,  $V_{a'b'}$ ,  $V_{b'c'}$ , and  $V_{c'a'}$ ), secondary circulating current  $I_{\Delta S}$ , and primary neutral current  $I_n$ . When done, use the variac to reduce the applied voltage to zero, set the three-phase breaker to 'off', and unplug the power cord. Do **NOT** disconnect any other wires until reading the next experiment.
- 3) Use this information to calculate the line-to-line turns ratios  $a_{Y-\Delta}$  and phase turns ratios  $a_\phi$  for each appropriate voltage pair.
- 4) Tabulate the data taken/calculated in steps 2) and 3). Format- column 1 is description of quantity of interest in the order taken or calculated (e.g.,  $V_{an}$ , ...), column 2 is the actual values, column 3 is for comparable values from Experiment 1 or predicted values using text (if applicable), and column 4 is for % difference (e.g., (% diff. =  $| \text{meas.} - \text{predicted} / \text{comparable} | / \text{measured} * 100\%$ )).
- 5) Determine the ratio of the average line-to-line turns ratio  $a_{Y-\Delta, \text{ave}}$  to the average phase turns ratio  $a_{\phi, \text{ave}}$ . How does this ratio compare to theory?

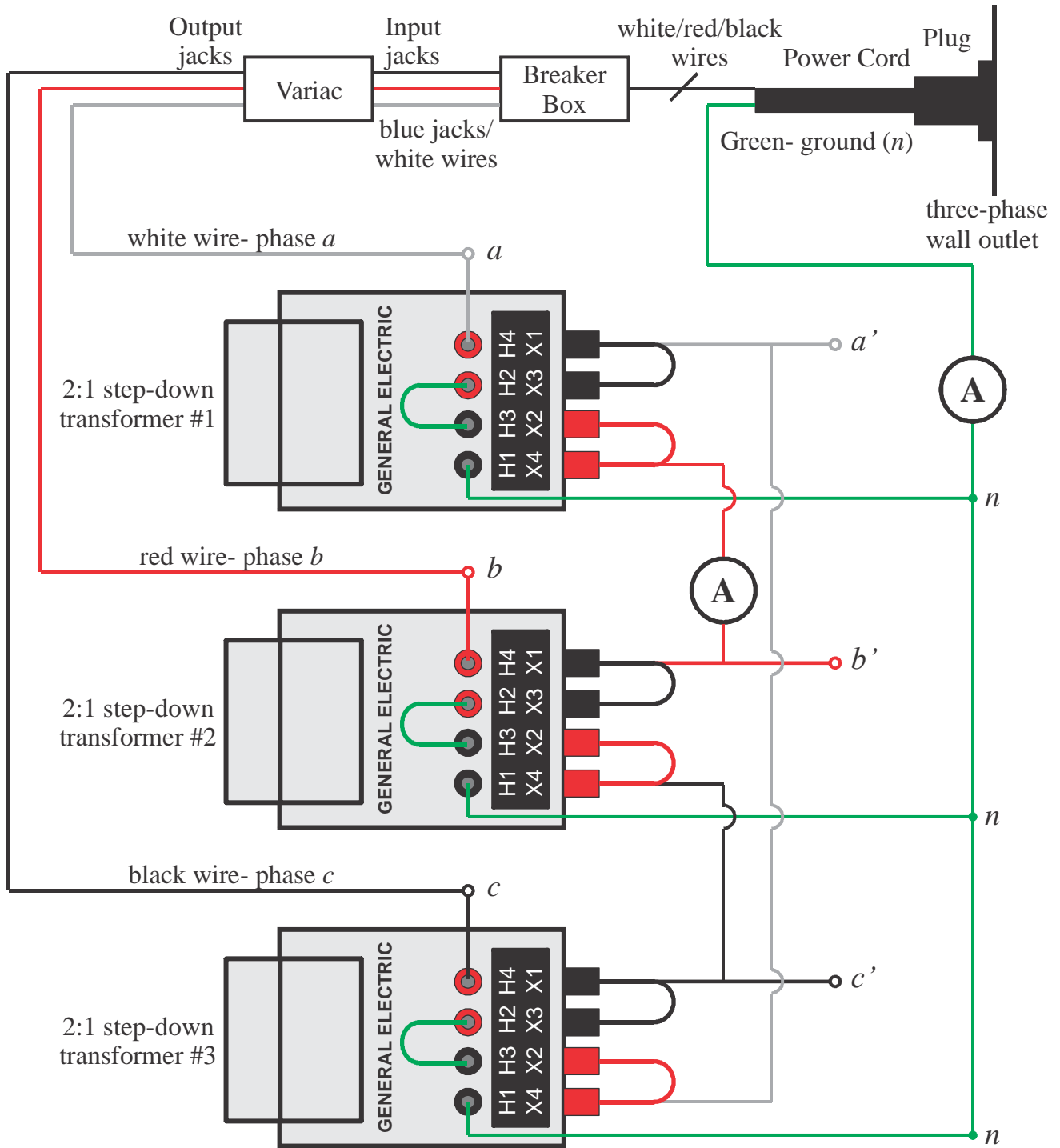

**Figure 4** 3-phase transformer connections for open circuit voltage tests on the Y-Δ configuration.

**Experiment 4 3-phase Delta-Wye ( $\Delta$ -Y) Configuration**

- 1) A block diagram of the necessary connections is shown in Figure 5. In this case, the voltmeter connections have been omitted for clarity. Do **NOT** plug in the power cord until all connections have been made, variac set to zero, and three-phase breaker set to 'off'. After plugging in the three-phase power cord and setting the three-phase breaker to 'on', use the variac to slowly raise the applied voltage to  $\sim 100 V_{\text{rms}}$ .
- 2) Then, measure and record the primary line-to-line/phase voltages (e.g.,  $V_{ab}$ ,  $V_{bc}$ , and  $V_{ca}$ ), secondary phase voltages (e.g.,  $V_{a'n}$ ,  $V_{b'n}$ , and  $V_{c'n}$ ), secondary line-to-line voltages (e.g.,  $V_{a'b'}$ ,  $V_{b'c'}$ , and  $V_{c'a'}$ ), primary circulating current  $I_{\Delta P}$ , and secondary neutral current  $I_n$ . When done, use the variac to reduce the applied voltage to zero, set the three-phase breaker to 'off', and unplug the power cord. Do **NOT** disconnect any other wires until reading the next experiment.
- 3) Use this information to calculate the line-to-line turns ratios  $a_{\Delta-Y}$  and phase turns ratios  $a_\phi$  for each appropriate voltage pair.
- 4) Tabulate the data taken/calculated in steps 2) and 3). Format- column 1 is description of quantity of interest in the order taken or calculated (e.g.,  $V_{an}$ , ...), column 2 is the actual values, column 3 is for comparable values from Experiment 1 or predicted values using text (if applicable), and column 4 is for % difference (e.g., (% diff. =  $| \text{meas.} - \text{predicted} / \text{comparable} | / \text{measured} * 100\%$ )).
- 5) Determine the ratio of the average line-to-line turns ratio  $a_{\Delta-Y, \text{ave}}$  to the average phase turns ratio  $a_{\phi, \text{ave}}$ . How does this ratio compare to theory?

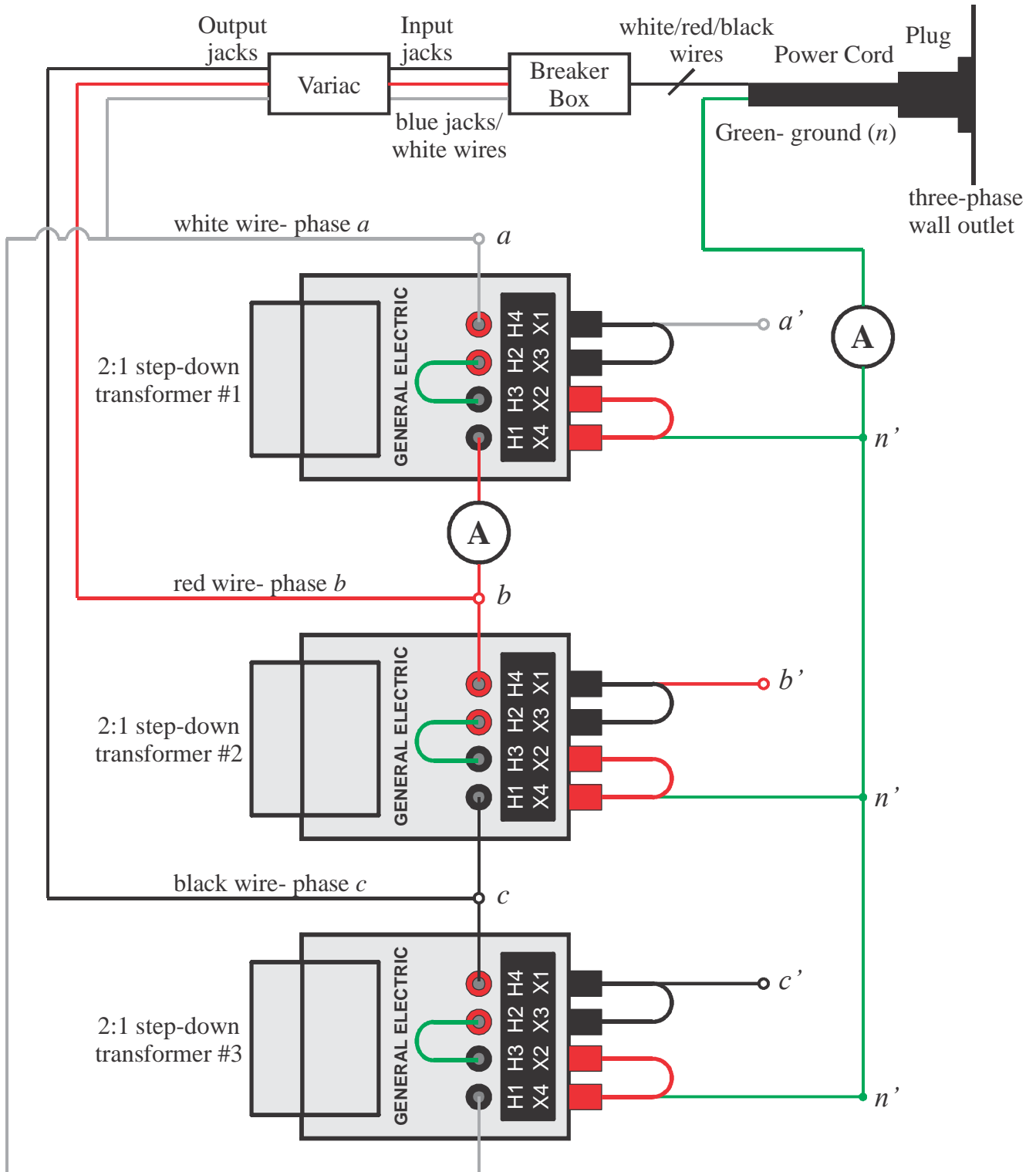

**Figure 5** 3-phase transformer connections for open circuit voltage tests on the  $\Delta$ -Y configuration.

### **Experiment 5 3-phase Delta-Delta ( $\Delta$ - $\Delta$ ) Configuration**

- 1) A block diagram of the necessary connections is shown in Figure 6. In this case, the voltmeter connections have been omitted for clarity. Do **NOT** plug in the power cord until all connections have been made, variac set to zero, and three-phase breaker set to 'off'. After plugging in the three-phase power cord and setting the three-phase breaker to 'on', use the variac to slowly raise the applied voltage to  $\sim 100 V_{\text{rms}}$ .
- 2) Then, measure and record the primary line-to-line/phase voltages (e.g.,  $V_{ab}$ ,  $V_{bc}$ , and  $V_{ca}$ ), secondary line-to-line/phase voltages (e.g.,  $V_{a'b'}$ ,  $V_{b'c'}$ , and  $V_{c'a'}$ ), primary circulating current  $I_{\Delta P}$ , and secondary circulating current  $I_{\Delta S}$ . When done, use the variac to reduce the applied voltage to zero, set the three-phase breaker to 'off', and unplug the power cord. Do NOT disconnect any other wires until reading the next experiment.
- 3) Use this information to calculate the line-to-line turns ratios  $a_{\Delta-\Delta}$  and phase turns ratios  $a_{\phi}$  (same number in this case) for each appropriate voltage pair.
- 4) Tabulate the data taken/calculated in steps 2) and 3). Format- column 1 is description of quantity of interest in the order taken or calculated (e.g.,  $V_{ab}$ , ...), column 2 is the actual values, column 3 is for comparable values from Experiment 1 or predicted values using text (if applicable), and column 4 is for % difference (e.g., (% diff. =  $|\text{meas.}-\text{predicted}/\text{comparable}|/\text{measured} * 100\%$ ).
- 5) Determine the ratio of the average line-to-line turns ratio  $a_{\Delta-\Delta, \text{ave}}$  to the average phase turns ratio  $a_{\phi, \text{ave}}$ . How does this ratio compare to theory?

### **Summary and Conclusions**

Summarize and discuss significant findings. How well does each type of 3-phase transformer perform? Are the neutral and circulating currents (as applicable) as expected? Are your measured results consistent with theory? Why/why not?

### **Lab Report**

- The results should be organized into a typed report. Where possible tabulate results.
- Unless otherwise specified, follow format guidelines contained in course syllabus.
- Include a cover page, Introduction, a body broken down into subsections/paragraphs based on the steps in assignment, and a Summary & Conclusions.
- Put **calculations**, results, and plots/figures in the body of the report in the order specified. Appendices are **NOT** to be used as a "dumping ground" for the calculations, results, and figures. However, long mathematical derivations may be attached as Appendices or done in the logbook **if referenced in the text** of the report. Your logbook is definitely a reference item.

**Report and logbook due Monday, March 20, 2012.**

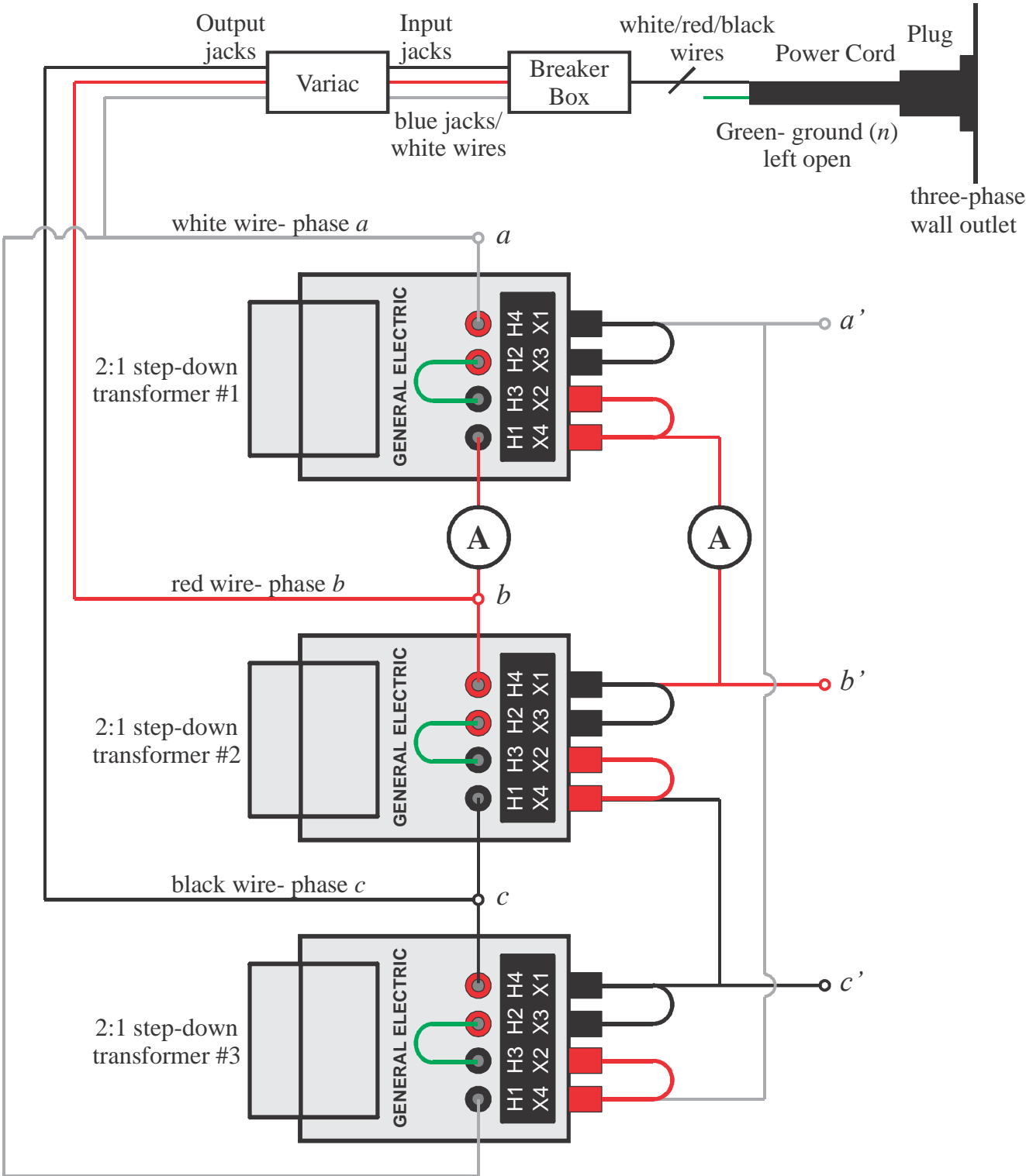

**Figure 6** 3-phase transformer connections for open circuit voltage tests on the  $\Delta$ - $\Delta$  configuration.